

# The Syntax of Modal Auxiliaries in Tlacolula Valley Zapotec\*

Mario E. Chávez-Peón

University of British Columbia  
mariochp@interchange.ubc.ca

Calisto Mudzingwa

University of British Columbia  
calliee@interchange.ubc.ca

Key words: Syntax, Morphology, modals, auxiliary verbs, Zapotec.

## 1. Introduction

This paper investigates the clausal architecture in Tlacolula Valley Zapotec<sup>1</sup> (TVZ) focusing on structures containing a modal auxiliary (Munro, 2006), such as examples (1) and (2).

- (1) *R-ii'le'eh r-gwèè'* Chiecw Dii'zhsa<sup>2</sup> 'Chico can speak Zapotec'  
HAB<sup>3</sup>-AUX HAB-speak Chico Zapotec
- (2) *R-quii'ny ny-a'u=wa'* 'I should have eaten'  
HAB-AUX SUBJ-eat=1s

In TVZ, modal auxiliaries and main verbs obligatorily appear with an aspect/mood prefix; henceforth, inflectional prefixes. The absence of an inflectional prefix, either in the complement verb, or in the auxiliary verb, results in an ungrammatical sentence. Consider examples (3) and (4).

- (3) a. \**R-ii'le'eh -gwèè'* Chiecw Dizhsa b. \**-ii'le'eh r-gwèè'* Chiecw Dizhsa
- (4) a. \**R-quii'ny -a'u=wa'* b. \**-quii'ny ny-a'u=wa'*

The pattern above differs from the one observed in other languages, where in an auxiliary plus complement verb construction, only the auxiliary contains inflectional

---

\* We are grateful to my consultants Chiecw Lopez, Tiu Rogel Martínez, Lia Esther and Lia Bri Núñez for sharing her language and culture. Thanks to my committee Martina Wiltschko, Patricia Shaw, and Joe Stemberger, as well as Rose-Marie Déchaine, Doug Pulleyblank, Noureddine Elouazizi, Mike Barrie, Pam Munro and Felicia Lee for discussion and suggestions. This paper has benefited from comments received from Calisto Mudzingwa, Andrés Salanova, Solveiga Armoskaite, Clare Cook and Donald Derrick as well as Francisco Arellanes and Rosa Rojas. All mistakes remain our own.

<sup>1</sup> Tlacolula Valley Zapotec is an Otomanguean language spoken in southern Mexico, in the Tlacolula District of Oaxaca. Most data come from the variety of the language spoken in the pueblo of San Lucas Quiavini, some examples are from San Bartolomé Quialaná and Santa Ana del Valle. Munro (2006), on which my paper is largely based, states that the basic description of the data presented here is valid for the whole language group as a whole.

<sup>2</sup> All Zapotec data come from personal fieldwork unless indicated otherwise.

<sup>3</sup> The glosses used in this paper are as follows: ADV=Adverb, APPL=Applicative, ASPP=Aspect Phrase, C=Complementizer, CAUS=Causative, CONJ=Conjunction, DEF=Definite, DIR=Directional, HAB=Habitual, INFL=Inflectional, INT=Intensifier, IP=Inflectional Phrase, IRR=Irrealis, MP=Mood Phrase, NEUT=Neutral, PERF=Perfective, POSS=Possessive, PROG=Progressive, SUBJ=Subjunctive, T=Tense, V=Verb.

information, such as tense and agreement. For instance, English constructions display this pattern and these constructions are analyzed as monoclausal (see, e.g., Radford, 1988, and Stowell, 2004). TVZ constructions which obligatorily require inflectional information on both the auxiliary and the main verb raises the following question: What is the nature of the clause structure in TVZ in constructions involving auxiliaries: biclausal or monoclausal?

This paper then aims to analyze the syntax of modal auxiliaries in TVZ. The analysis adopted in this paper is founded on the Principles and Parameters framework (Chomsky 1981), in its minimalist version (Chomsky & Lasnik, 1993; Chomsky, 1995).

Based on language internal evidence, we claim that inflectional prefixes in TVZ are generated under *I*. Further, we argue that a Modal Auxiliary projects its own phrase, *Auxiliary Phrase (AuxP)*; Radford, 2004: 112). It is also shown that TVZ auxiliaries always take inflected verbs as complements, which are analyzed as *IPs*. This can be schematized in the following subcategorization frame.

(5) Modal Aux: [ \_\_ IP ]

As both the auxiliary verb and the complement have inflectional prefixes (are inflected), we assume that they constitute a biclausal structure; a position that the paper argues for. In order to account for this structure, we adopt a reduced clausal approach, arguing that the complement of the *Aux*, namely the *IP*, is a reduced clause, which does not project a CP (see, Wurmbrand, 2003 for discussion regarding reduced clauses); the lack of projection of a CP follows from the fact that no constituent can appear between auxiliary and the inflected verb. This is illustrated in (6).

(6) Modal (auxiliary) construction

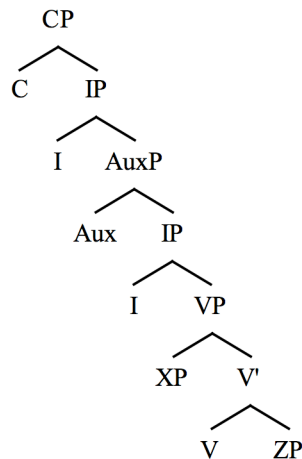

This study contributes to a deeper understanding of modal auxiliaries in TVZ (based on Munro, 2006). It sheds light on the data by providing a theoretical analysis of the syntax of auxiliary verbs in the language, including implications of this analysis for clausal architecture of TVZ, in particular (cf. Lee, 2006), and in natural languages in general.

The paper is organized as follows: Section 2 provides a TVZ background, presenting characteristics of the language that will be relevant for the analysis. The following section presents particular characteristics of main and auxiliary verbs in TVZ. Section 4 presents a description of modal auxiliaries in TVZ, based on Munro



- (8) TVZ verbal morphology (based on Lee, 2006: 27)  
 INFL (DIR/CAUS) ROOT (APPL/INT)(ADV)(SUBJECT CLITIC)(OBJECT CLITIC)
- (9) r-z-ihnnih=a'  
 HAB-CAUS-root(gets light)=subject clitic(s/he)  
 "I turn on (a light)"
- (10) bdàu'wèngi  
 b-dàu'=eng=i  
 perf-root(taste)=subject clitic(s/he)=object clitic(it)  
 "s/he ate it"

### 3.1 Morpheme co-occurrence: Verbs vs. Auxs

The goal of this section is to compare the affixes that can be attached to main verbs and those that can appear with auxiliaries. The differences will help in defining the characteristics of an auxiliary verb in TVZ.

In what follows, we illustrate the morpheme co-occurrence of main verbs using the verb *rda'uh* 'eats' in perfective form. Examples are presented on the left hand side, whereas morpheme labels appear on the right hand side.

- (11) *B-da'uh*<sup>6</sup> nàa' INFL-ROOT  
 PERF-eat 1s  
 'I ate'
- (12) *B-t-a'uh* nàa'  
 INFL-DIR-ROOT  
 PERF-DIR-eat 1s  
 'I went to eat / I went and ate'
- (13) *B-z-a'uh* nàa' Gye'eihlly  
 INFL-CAUS-ROOT  
 PERF-CAUS-eat 1s Mike  
 'I made Mike eat'
- (14) *B-da'uh=a'*  
 INFL-ROOT=SUBJECT CLITIC  
 PERF-eat=1s  
 'I ate'

As the examples above illustrate, main verbs can co-occur with different prefixes and suffixes. In comparison, auxiliary verbs can only co-occur with a subset of affixes: inflectional prefixes. As an illustration, we present the auxiliary *ri'lle'eh* in habitual form.

- (15) *R-ì'lle'eh* r-gwèe' Chie'cw Dii'zhsah INFL-AUX  
 HAB-AUX HAB-speak Chico Zapotec  
 'Chico can speak Zapotec'

<sup>6</sup> For this root, an obstruent appears when the root is preceded by another obstruent.

- (16) \*R-*i'cy*<sup>7</sup>-*ii'le'eh*    r-gwèe'    Chie'cw    Dii'zhsah    \*INFL-DIR-AUX  
 HAB-DIR-AUX    HAB-speak    Chico    Zapotec  
 intended: '\*Chico can go to/and speak Zapotec'
- (17) \*R-*z-ii'le'eh*    r-gwèe'    Chie'cw    Dii'zhsah    \*INFL-CAUS-AUX  
 HAB-CAUS-AUX    HAB-speak    Chico    Zapotec  
 intended: '\*Chico can causes (somebody?) to speak Zapotec'
- (18) R-*ii'le'(\*=ih)*    r-gwèe'\*(=ih)    Dii'zhsah    \*INFL-AUX=SUBJ CLITIC  
 HAB-AUX=3S    HAB-speak    =3s    Zapotec  
 intended: '\*S/he can speak Zapotec'

The above comparison between main and auxiliary verbs is summarized in the table below.

Table 2. Morpheme co-occurrence: Summary table.

| Verbal form              | Auxiliary form            |
|--------------------------|---------------------------|
| INFL-ROOT                | INFL-AUX                  |
| INFL-DIR-ROOT            | *INFL-DIR-AUX             |
| INFL-CAUS-ROOT           | *INFL-CAUS-AUX            |
| INFL-ROOT=SUBJECT CLITIC | *INFL-AUX= SUBJECT CLITIC |

### 3.2 Subcategorization: Verbs vs. Auxs

Now we turn to the differences between main and auxiliary verbs in terms of the complements they take, namely, their subcategorization patterns. First, main verbs select Determiner Phrases (DPs), illustrated in (19) and schematized in (20).

- (19) R-*inydyahg*    [ Rrodriegw    Lia Esther ]    V\_S\_O  
 HAB-listen    Rodrigo    girl Esther  
 'Rodrigo listens to Esther'

- (20) Verb [ \_\_\_ DP (DP) ]                    e.g. *rinydyahg* 'listens to' [ \_\_\_ DP DP]

In contrast, auxiliaries cannot take DPs as complements:

- (21) \*R-*quii'ny* [ Rrodriegw (Esther) ]                    \*Aux\_S\_O  
 HAB-AUX    Rodrigo    Esther  
 intended: '\*Rodrigo should (to/of) Esther'

- (22) \*Aux [ \_\_\_ DP (DP) ]

Recall that auxiliary verbs select inflected verbs with its arguments (IP):

---

<sup>7</sup> Directional affixes change depending on the prefix that precedes them; *i'cy-* is a common directional form after habitual, *r-*.

(23) R-quii'ny<sup>8</sup> [ n-inydyahg Rrodriegw Lia Esther]  
 HAB-AUX SUBJ-listen Rodrigo girl Esther  
 'Rodrigo should listen to Esther'

Aux\_V\_S\_O

The following table shows that main verbs can take DP's as arguments whereas auxiliaries cannot; instead, the latter select inflected verbs. (A subset of main verbs can also select inflected verbs; this fact, however, is not significant for the purpose of this paper.)

Table 3. Subcategorization: Summary table

|      | DP | Inflected verbs |
|------|----|-----------------|
| Verb | √  | X <sup>9</sup>  |
| Aux  | X  | √               |

Main and auxiliaries verbs are different. The former exhibit a full range of affixes and primarily selects DP's as arguments; whereas the latter have a reduced morphology and are unable to take nominal arguments. Instead they select inflected verbs as complements (arguments). In sum, we assume these characteristics as necessary conditions for a verb to be classified as an auxiliary in TVZ: reduced morphology and selecting verbs as complements.

#### 4. Modal Auxiliaries Classification

Having established that auxiliaries are different from main verbs, we now turn to present a description of the TVZ auxiliaries and present evidence for the internal classification based on semantic characteristics (Munro 2006; see this article for a detailed description of modal expression in general in Valley Zapotec).

TVZ encodes modality in two different ways (Munro, 2006): by means of a subset of inflectional prefixes (see table 1) or by means of auxiliaries. All auxiliaries in this language express modality and Munro calls them modal auxiliaries. We will adopt this term. Further, she groups TVZ modal auxiliaries into two classes (2006: 189): *necessity* (or obligation) and *possibility* (or capability) modal auxiliaries. In what follows, the characteristics of each class are described.

##### 4.1. Necessity modal auxiliaries

In order to describe the TVZ necessity modal auxiliaries, first, we present a list of these verbs, table 4 below, followed by their inflectional characteristics; finally, we show the selectional properties of these verbs, namely, the kind of complements they take.

<sup>8</sup> There is an apparent contradiction in the use of *Rquii'ny* (as well as other auxiliaries). It can be used as a main verb, but with a different meaning:

- (a) R-*quii'ny* Rrodriegw rrefre'scw 'Rodrigo (usually) drinks soda'  
 HAB-drinksRodrigo soda

For these cases, I assume there are two different lexical entries for the verb *rquii'ny*, one as a main verb (non-modal use) and another as an modal auxiliary. This is the criteria for all auxiliaries in the present paper. See Radford (2004: 119), among others, for similar treatment of English verb *have*.

<sup>9</sup> I remebered I went

Table 4. Necessity modal auxiliaries  
(Munro, 2006: 31; Munro, Lopez, *et al*, 1999)

| Entry              | Translation                               |
|--------------------|---|
| <i>rquii'ny</i>    | should, needs to                          |
| <i>ryàall</i>      | should, deserves to, should get a turn to |
| <i>ruhnygaan</i>   | should, had better                        |
| <i>nàa pahr</i>    | must, ought to, should                    |
| <i>nàa cwe'enn</i> | is supposed to                            |
| <i>nadii'zh</i>    | is supposed to, ought to, has to          |

Necessity modal auxiliaries are invariant in their form and, as the table above shows. They have two patterns, those that are used in habitual form only: *rquii'ny*, *ryàall* and *ruhnygaan*; and those that are used in neutral form only *nàa pahr*, *nàa cwe'enn* and *nadii'zh*.

(24) Necessity auxiliaries inflectional pattern:

|                         |   |                 |
|-------------------------|---|-----------------|
| habitual form (only):   | <i>r-quii'ny</i><br><b>HAB-AUX</b>      | 'should / need' |
| or neutral form (only): | <i>nàa pahr</i><br><b>NEUT.AUX prep</b> | 'must'          |

It is of particular interest that two of these auxiliaries are compound forms: *nàa pahr* and *nàa cwe'enn*. The former consists of *nàa*, a copular form, plus the preposition *pahr* 'for' (borrowed from Spanish preposition *para*). The latter begins with the same copular form, followed by the verb *cwe'enn* 'to count' (also from Spanish). Both compounds, however, function as an auxiliary encoding an obligation meaning. According to Munro (2006: 191), "their modal uses are metaphorical or lexically derived". The specific derivation of these compounds, however, is beyond the scope of this paper.

Lastly, regarding their selectional properties, these auxiliaries take verbs in irrealis or subjunctive form only, as illustrated below:

(25) R-quii'ny [ *g-a'u=wa'* ]  
HAB-AUX **IRR-eat=1s**  
'I should eat / I need to eat'

(26) R-quii'ny [ *ny-a'uw=a'* ] (Munro 2006: 190)  
HAB-AUX **SUBJ-eat=1s**  
'I should have eaten.'

(27) N-àa pahr [ *ch-a'=a'* ] (Munro 2006: 181)  
NEUT-AUX prep **IRR-go-1s**  
'I should go'

(28) N-àa pahr [ *ny-a'=a'* ] (Munro, Lopez *et al*, 1999: 172)  
NEUT-AUX prep **SUBJ-go-1s**  
'I should have gone'

#### 4.2. Possibility modal auxiliaries

There are three possibility modal auxiliaries in TVZ, listed below.

Table 5. Possibility auxiliaries  
(Munro, 2006: 31, Munro, Lopez, *et al*, 1999)

| Entry             | Translation                                  |
|-------------------|--|
| <i>r-ì'lle'eh</i> | can  |
| <i>r-ahc</i>      | can  |
| <i>r-ahcgaan</i>  | can (succeeds in (doing); completely (does)) |

In contrast with necessity modal auxiliaries, possibility ones vary in their form, taking different inflectional prefixes, as shown below:

- (29) HAB: *r-* *-ì'lle'eh*<sup>10</sup> 'can'  
 DEF: *Z-*  
 IRR: *ch-*  
 PERF: *gu-*

The selectional properties of possibility modals also differ in comparison to the necessity ones. The inflectional prefix of the complement verb agrees with that of the possibility auxiliary, illustrated in the following examples.

- (30) *R-ahc* [ *r-bèe'b* *Jwaany caba'i* ] 'John can ride the horse.'  
**HAB-AUX HAB-ride** John horse

- (31) *Gùu'-lle'eh* [ *b-zh:ùu'nny=a'* ] 'I could run'  
**PERF-AUX PERF-run=1s**

- (32) *Ch-ì'lle'eh* [ *y-zhye'ill=yuu'* *bentaan* ]èè? 'Can you open the window?'  
**IRR-AUX IRR-open-2s window Q**

Example (30) shows the inflected modal and the main verb in habitual form; (31) illustrates the pattern in perfective and (32) in irrealis.

In sum, in terms of their form, TVZ modal auxiliaries take different inflectional prefixes. Necessity modals seem to be invariant in form, some in habitual and others in neutral forms; whereas possibility modals vary in terms of the prefix they take. As for the complements they select, necessity modals require verbs in irrealis or subjunctive forms only; whereas possibility modals have to have the same inflectional prefix as their complement verb.

#### 5. TVZ Inflectional Prefixes

In TVZ, modal auxiliaries and main verbs obligatorily appear with an inflectional prefix (table 1); thus, in order to explain the syntax of TVZ modals, first it is necessary to

<sup>10</sup> The first vowel of the verb *rii'lle'eh* have changes according to the prefix: def. *zàa'lle'eh*, irr. *chii'lle'eh*, perf. *gùu'lle'eh* (Munro, Lopez, et al 1999).



suggesting the complementary distribution of these markers. To illustrate this matter, we present the paradigm of the verb *rzh:ùu'nny* 'runs', followed by ungrammatical forms with more than one inflectional prefix<sup>11</sup>.

- (35) Habitual: *rzh:ùu'nny* 'runs'  
 Perfective: *bzh:ùu'nny* 'ran'  
 Progressive: *cazh:ùu'nny* 'is running'  
 Neutral: —  
 Irrealis: *yzh:ùu'nny* 'will run'  
 Subjunctive: *nzh:ùu'nny* '(if...) had run'  
 Definite: *x:ùu'nny* 'will surely run'

- (36) irrealis plus habitual:  
 \**i-r-zh:ùu'nny=ih*  
 IRR-HAB-run=3s  
 intended: \*'He will run (regularly)'

- (37) progressive plus perfective:  
 \**ca-b-zh:ùu'nny=a'*  
 PROG-PERF-run=1s  
 intended: \*'I will have run'

The examples above illustrate that a single verb cannot take more than one inflectional prefix. In other words, this language allows no stacking of these prefixes.

If these prefixes all instantiate the same syntactic head, then it is predicted that they are in complementary distribution. This morphosyntactic proposal is schematized as follows (cf. Lee, 2006):

- (38) Complementary distribution of TVZ *Infl* prefixes

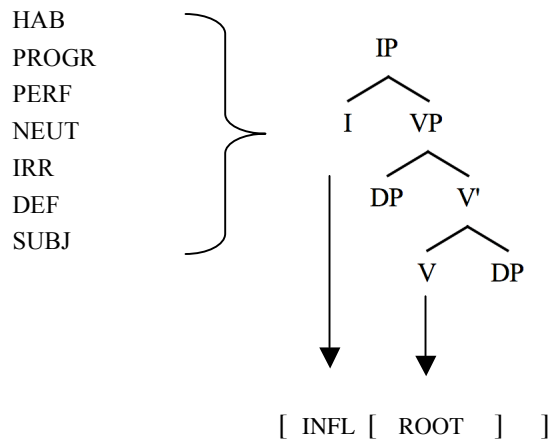

On the assumption that productive word formation processes occur at the syntactic level, this suggests that inflectional prefixes occupy the same syntactic position.

<sup>11</sup> In the current paper, I just present two ungrammatical examples of stacking; however, all possible combinations of these prefixes with different verbs, were tested resulting ungrammatical.

- c. There are no other *Infl* (mood/tense/asp) morphemes attested in TVZ

The last argument in favor of the analysis of inflectional markers as a unified class is that only these prefixes, the seven aspect/mood markers shown in table 1, encode inflectional information that provides grammaticality to the sentence, no other inflectional markers are attested in TVZ.<sup>12</sup>

## 5.2 Alternative analysis

In this section, we discuss two alternatives to the analysis outlined above regarding the syntax of TVZ inflectional prefixes: a morphological restriction (template) approach and a multiple functional projections perspective. The former alternative predicts that these prefixes are in complementary distribution based on a morphological restriction: only one prefix per verb is allowed due a morphological template. This possibility, however, is rejected based on the fact that two prefixes may precede the verb.

- (39) r-z-ihnnih=a' INFL-CAUS-ROOT  
 HAB-CAUS-gets light=3s  
 'I turn on (a light)'

- (40) r-gu-èi'ny=ih INFL-DIR-ROOT  
 HAB-DIR(go)-does=3s  
 'The goes and does (it)'

In the examples above, the first prefix in both cases is an (habitual) inflectional marker, but crucially not the second; either a causative or directional prefix optionally occupies this position. Moreover, the latter prefixes are not sufficient to render the example grammatical. The presence of an inflectional prefix is necessary, as shown below.

- (39)' \*z-ihnnih=a' \*CAUS-ROOT  
 CAUS-gets light=1s

- (40)' \*gu-èi'ny=ih \*DIR-ROOT  
 DIR(go)-does=ih

The other possible syntactic representation for TVZ inflectional prefixes is the multiple functional projections approach (a la Cinque, 1999), i.e., MoodP > TP > AspP (see Lee, 2006 for a comparable approach); under this analysis, modal prefixes will be generated under the syntactic head Mood, aspectual ones under Asp. This approach, however, predicts the co-occurrence of inflectional prefixes; nevertheless, stacking of these prefixes is not attested in Zapotecan languages (Kaufman, 1994; Smith, 1994).

<sup>12</sup> Munro (2006: 193) notice that Valley Zapotec express epistemic modality by means of the clitic =zhyi.

- (a) B-da'uh=zhy=ëng bxàady. (Munro, 2006: 194)  
 perf-eat=epis=3s.prox grasshopper  
 'He must have eaten the grasshopper.'

Even though the suffix =zhy encodes modality, it does not belong to the same category of that of inflectional affixes in that the presence of =zhy is not sufficient to obtain a grammatical form once it is attached to a verb: ((a)\*)-da'uh=zhy=ëng; an inflectional prefix is still required. This suggests that the suffix =zhy is not in *Infl*. The specific syntactic analysis of this suffix is left aside for future research.



In terms of the selectional properties of auxiliaries, we have observed that all main complement verbs have to be inflected as well. Consequently, we propose that modal auxiliaries select IP's, instead of VP's (see example (44)). This can be represented in the subcategorization frame below:

(47) Modal Aux: [ \_\_ IP ]

The implementation of this structure requires a reduced clausal approach, as the embedded clause does not project a CP (Wurmbrand, 2003: 11; see also Tappe, 1984, Fanselow, 1989, Rooryck, 2000). The embedded IP is where the main/complement verb and its arguments originate. The idea can be schematized as follows:

(48) [CP [ IP [ AuxP [ IP [ VP ]]]]]

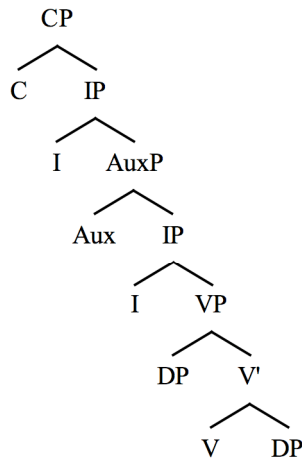

Alternatively, modal auxiliaries might select CP's as their complements (instead of IP's). However, no constituent can appear between the modal auxiliary and the complement verb. We illustrate this fact with examples of focus (noticed by Munro, 2006: 188) and questions (see appendix 1 for more details).

In order to focus the subject of the sentence in (41), *Chie'cw*, it has to be fronted before both the modal auxiliary and the main verb, shown in (49a). In contrast, the presence of the subject between auxiliary and complement verb is ungrammatical (49b).

- (49) a. [ *Chie'cw* ]    r-ì'lle'eh    r-gwèè'    Dii'zhsah  
          Chico        HAB-AUX    HAB-speak    Zapotec  
          "Chico can speak Zapotec"
- b.    \*R-ì'lle'eh    [ *Chie'cw* ]    r-gwèè' Dii'zhsah  
       HAB-can     Chico            HAB-speak Zapotec  
       "Chico can speak Zapotec"

In regard to questions, wh-words are obligatorily fronted in TVZ; wh-in-situ is disallowed (Lee 2006: 7, see also ch. 4). Below, the wh-subject appears at the beginning

of the sentence, whereas its presence between the modal auxiliary and the main verb is disallowed.

- (50) a. [ *Tu* ]            R-ii'lle'eh r-gwèè' Dii'zhsah?        'Who can speak Zapotec?'  
           WH.ANIM    HAB-AUX HAB-speak Zapotec
- b. \*R-ii'lle'eh [ *tu* ]        rgwèè'    Dii'zhsah?        '\*Who can speak Zapotec?'  
                   HAB-AUX WH.ANIM HAB-speak Zapotec

The above data suggest that there is no landing position between the modal aux and the complement verb; hence, no CP (along with any other projection on the 'left periphery' (Rizzi 1997), e.g. topicalization, force, negation in some languages, among other).

## 7. Consequences

The analysis adopted in this study has implications for the linear order, as well as case assignment in TVZ. In turn, each of these is discussed in detail, beginning with linear order.

### 7.1. Linear order in TVZ

The question of how VSO word order —prevalent in Zapotecan languages— is derived has been long debated by linguists. Following the VP-Internal Subject Hypothesis (Kitagawa, 1986; Koopman & Sportiche, 1991), in VSO languages the verb has to move from its base generated position in order to precede its subject. Under this approach, current proposals can be reduced to three possibilities: the verb may move outside the VP to C(omplementizer), to I(nfl), or it may move outside the VP to some higher projection above its complements, but below I. Irish is a typical example of the first case: V to C movement (McCloskey, 1983 & 2003); Classic Arabic has been analyzed as a case of V to I movement (Koopman & Sportiche 1991); finally, Berber is an example of verb movement, where the verb moves from the head position in VP, to a left edge position below IP (Elouazizi 2004, 2006). The landing position of the verb in the last case is commonly assumed to be a functional projection simply called *FP* (Uriagereka, 1995 & 1997; Ouhalla, 2005, inter alia). This is summarized below:

(51) Verb movement in VSO languages

- |           |  |
|-----------|--|
| 1. V -> C | (e.g. Irish; McCloskey, 1983 & 2003)             |
| 2. V -> I | (e.g. Classic Arabic; Koopman & Sportiche, 1991) |
| 3. V -> F | (e.g. Berber; Elouazizi, 2004 & 2006)            |

In TVZ, there is no indication in favor of V to C movement. In fact, there is evidence against this possibility as other constituents, such as auxiliary verbs and negation, regularly precede the verb in this language. Auxiliary verbs have been analyzed in section 6, and in TVZ negation, is presented below. (See appendix 1 for more detail about the interaction of these constituents and the main verb.)

- (52) Queity    r-gwèè'-di            Chie'cw Dii'zhsah    "Chico doesn't speak Zapotec"  
           NEG        HAB-speak-NEG        Chico    Zapotec



(55) Feature checking via AGREE

- a. A probe  $\alpha$  has uninterpretable  $\phi$ -features.
- b. A goal  $\beta$  has matching  $\phi$ -features.
- c. Uninterpretable  $\phi$ -features are valued, and delete.

Zapotec  
 C  
 DP<sub>subject</sub>

In TVZ, the probe is the Complementizer, which finds its goal in the DP subject. A feature matching takes place between these two categories via AGREE and their features are deleted.

**7.3. Full derivation**

To conclude this section, we present a full derivation of a TVZ sentence containing a modal auxiliary, taking into account the issues explained above: linear order as well as case assignment.

(56) R-ii'lle'eh r-gwèè' Chie'cw Dii'zhsah  
 HAB-can HAB-speak Chico Zapotec  
 "Chico can speak Zapotec"

Aux\_V\_S\_O

(57)

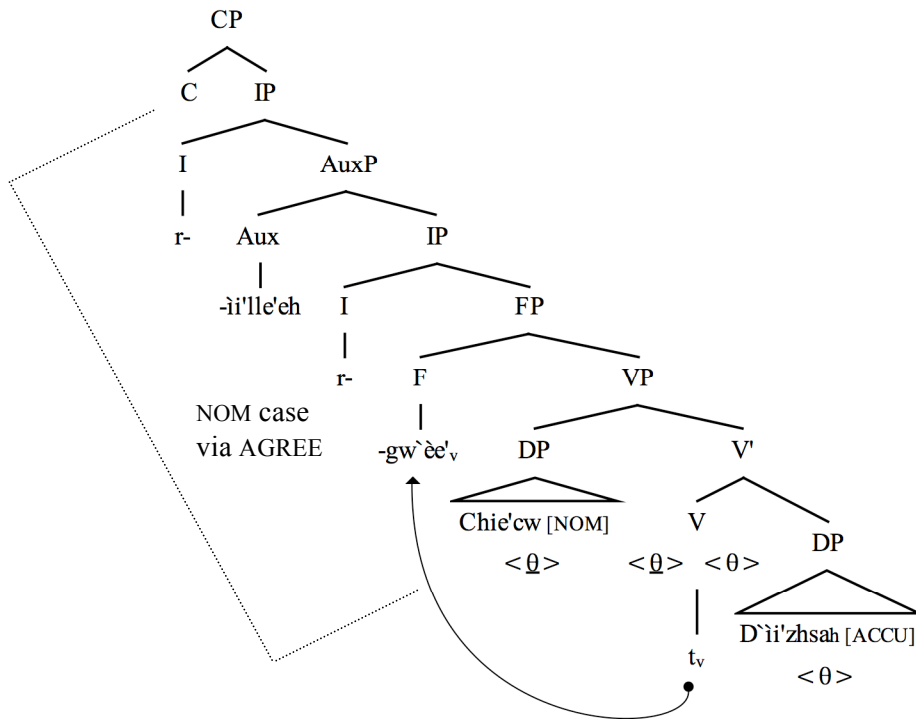

Thematic roles are assigned within VP without further complexity; it is a commonplace that auxiliaries do not assign theta roles (Heine, 1993; Wurmbrand, 2003). As we established, the verb assigns ACCU case and C assigns NOM case (via AGREE).

Finally, to obtain the correct linear order in this language, the verb moves outside the VP to a functional projection below IP, V to F movement, preceding its complements.

## 8. Conclusions

In this paper, we presented an analysis on the Syntax of modal auxiliaries in Tlacolula Valley Zapotec. First, we claimed that inflectional prefixes in TVZ (table 1) are generated under *I*. Second, we argued that modal auxiliaries project its own phrase, Auxiliary Phrase, and select *IPs* based on the fact that complement verbs are always inflected. Third, as both the auxiliary verb and the complement verb are inflected in a modal construction, we assume they form a biclausal structure; the lower *IP* (complement main verb) constitutes a reduced clause that does not project a *CP*.

This analysis provides a unified syntactic account for all modals in TVZ, though they display different individual syntactic and semantic characteristics. Further consequences of this approach include the existence of a functional projection below *IP* that provides a landing position for the verb, as well as nominative case assignment by *C*. Finally, an avenue for future research is the semantics of modal auxiliaries.

## References

- Alboiu, Gabriela. (In Press). Feature Inheritance and Case values in Nominative-Accusative Systems.
- Bobaljik, J.D. and D. Jonas. (1996). Subject positions and the roles of TP. *Linguistic Inquiry* 27, 195-236.
- Chávez-Peón, Mario E. (2006). San Lucas Quiavini Zapotec Inflectional prefixes: A morphosyntactic account. WSCLA 11: Poster presentation-UBC, Vancouver, April 1.
- Chomsky, Noam. (1981). *Lectures on government and binding*. Dordrecht: Foris.
- Chomsky, Noam. (1995). *The minimalist program*. Cambridge, Mass.: The MIT Press.
- Chomsky, Noam, and Howard Lasnik. (1993). The Theory of Principles and Parameters. In *Syntax: An International Handbook of Contemporary Research, vol. 1*, eds. Joachim Jacobs, Arnim von Stechow, Wolfgang Sternefeld, and Theo Vennemann, pp 506-569. Berlin:Walter de Gruyter.
- Cinque G. (1997). Adverbs and functional heads: a cross-linguistic perspective. Oxford University Press, Oxford.
- Fanselow, Gisbert. (1989). Coherent Infinitives in German: Restructuring vs. IP-Complementation. In: Bhatl, Löbel & Schmidt (eds.). *Syntactic Phrase Structure Phenomena in Noun Phrases and Sentences*. John Benjamins, Amsterdam, 1-16.
- Heine, Bernd. (1993). *Auxiliaries: cognitive forces and grammaticalization*. New York: Oxford University Press.
- Kaufman, T. (1994). Proto-Zapotec reconstructions. Ms., University of Pittsburgh.
- Kitagawa, Yoshihisa. (1986). *Subjects in Japanese And English*. Doctoral dissertation. University Of Massachusetts Amherst.
- Koopman, Hilda, and Dominique Sportiche. (1991). The Position of Subjects. *Lingua* 85, 211-258.
- Lee, Felicia. (2006). *Remnant raising and VSO clausal architecture: a case study of San Lucas Quiavini Zapotec*. Dordrecht, The Netherlands: Springer.
- McCloskey, James. (1997). Subjecthood and Subject Positions. In *Elements of Grammar*, ed. Haegeman, Liliane M. V., 197-235. Kluwer:Academic Publishers.
- Munro, Pamela. (2006). Modal expression in Valley Zapotec. In *The Expression of Modality*, ed. Frawley, William, 177-209. Berlin; New York: Mouton de Gruyter.
- Munro, Pamela and Felipe H. Lopez, with Olivia V. Méndez [Martínez], Rodrigo Garcia, and Michael R. Galant. (1999). *Di'csyonaary X:tè'n Dii'zh Sah Sann Lu'uc (San*

- Lucas Quiavini Zapotec Dictionary / Diccionario Zapoteco de San Lucas Quiavini*. Los Angeles: UCLA Chicano Studies Research Center Publications.
- Munro, Pamela, Brook Danielle Lillehaugen and Felipe H. Lopez. Forthc. *Cali Chiu? A Course in Valley Zapotec*.
- Ouhalla, Jamal. (2005). Agreement Features, Agreement and Antiagreement. *Natural Language and Linguistic Theory* 23:655-686.
- Pollock, Jean-Yves. (1989). Verb Movement, Universal Grammar, and the Structure of IP. *Linguistic Inquiry* 20: 365-424.
- Radford, Andrew. (1988). *Transformational grammar: a first course*. Cambridge Cambridgeshire ; New York: Cambridge University Press.
- Radford, Andrew. (2004). *Minimalist syntax: exploring the structure of English*. Cambridge, UK ; New York: Cambridge University Press.
- Rizzi, Luigi. (1997). The Fine Structure of the Left Periphery. In *Elements of grammar: handbook in generative syntax*, ed. Haegeman, Liliane M. V., pp. 281-337. Dordrecht; Boston: Kluwer Academic Publishers.
- Rouveret Alain & Jean-Roger Vergnaud. (1980). Specifying reference to the subject: French causatives and conditions on representations. *Linguistic Inquiry* 11:97-202.
- Rooryck, Johan. (2000). Configurations of Sentential complementation.
- Smith, Thomas. (1994). El estado actual de las lenguas zapotecas. el Colegio de México. Ms.
- Stowell, Tim. (2004). Tense and Modals. In *The Syntax of Time*, eds. Gueron, Jacqueline, and Jacqueline Lecarme, 621-635. Cambridge, Mass.: MIT Press.
- Tappe, Hans Thilo. (1984). On infinitival clauses without COMP. In: de Geest, Win & Yvan Pulseys (eds.). *Sentential Complementation*. Foris, Dordrencht, 227-237.
- Uriagereka, Juan. (1995). 'An F Position in Western Romance,' in K. Kiss (ed.), *Discourse Configurational Languages*, Oxford.
- Wurmbrand, Susanne. (2001). AGREE: The Other VP-Internal Subject Hypothesis. In *Proceedings of the 20th West Coast Conference on Formal Linguistics*, eds. Megerdooimian, Karine, and Leora Anne Bar-el, 635-648. Somerville, MA: Cascadilla.
- Wurmbrand, Susanne. (2003). *Infinitives: restructuring and clause structure*. Berlin; New York: Mouton de Gruyter.

### **Appendix 1: More on Syntactic properties of Modal auxiliaries**

This appendix presents the interaction of modal constructions with respect to the position of subject, negation and questions. Crucial examples for the analysis of modal auxiliaries were already presented in the paper; this section provides complementary data.

The following sentence will be base for the whole section.

(58) √ R-i'i'lle'eh r-gwèè' Chie'cw Dii'zhsah "Chico can speak Zapotec"  
 HAB-AUX HAB-speak Chico Zapotec

a) *Subject interaction:*

(59) a.\* Rii'ille'eh Chie'cw rgwèè' Dii'zhsah "Chico can speak Zapotec"

b. R-i'i'lle'eh (\*Chie'cw) r-gwèè' Chie'cw Dii'zhsah "Chico can speak Zapotec"

- c. √ R-i'lle'eh r-gwèe'=ih Dii'zhsah "He (out of sight) can speak Zapotec"  
       =3s (clitic)
- d. \* R-i'lle'=ih r-gwèe' Dii'zhsah "He (out of sight) can speak Zapotec"
- e. R-i'lle'(\*=ih) r-gwèe'=ih Dii'zhsah "He (out of sight) can speak Zapotec"

In sum, only one subject (or one subject clitic) is allowed in a modal construction, and it has to follow the complement verb (or precede the auxiliary if it is focused).

### b) Negation

A TVZ negative sentence begins with the word *que'ity* "not", followed by the verb with the suffix *-di'* (Munro, Lillehaugen and Lopez, 2006: 105; see also Lee 2006: ch. 4)

- (60) Queity r-gwèe'-di Chie'cw Dii'zhsah "Chico doesn't speak Zapotec"  
       NEG HAB-speak-NEG Chico Zap

The following examples illustrate the interaction of negation with modals.

- (61) a. √ Queity r-i'lle'eh-di r-gwèe' Chie'cw Dii'zhsah  
       NEG HAB-AUX-NEG HAB-speak Chico Zapotec  
       "Chico can't speak Zapotec"
- b. \* Queity Rii'lle'eh rgwèe'di Chie'cw Dii'zhsah "Chico can't speak Zapotec"
- c. \* Queity ri'lle'eh rgwèe' Chie'cw Dii'zhsah "Chico can't speak Zapotec"
- d. (\* Rii'lle'eh) queity rgwèe'(di) Chie'cw Dii'zhsah "Chico can't speak Zapotec"

All in all, the negation word *que'ity*, "not", must precede the modal (sentence initial) and the particle/suffix *-di* must attached to the modal.

### c) Questions

Questions in TVZ require *wh*-words to be fronted; *wh*-in-situ is disallowed (Lee 2006: 7, see also ch. 4). See examples below.

- (62) Bii'llyëng li'ebr. "He read the book"  
       B-i'i'lly-ëng li'ebr  
       PERF-read-3s.prox book
- (63) Xi bìi'llyëng? "What did he read?"  
       Xi b-i'i'lly-ëng  
       what PERF-read-3s.prox
- (64) \*B-i'i'lly-ëng xi? "What did he read?"  
       PERF-read-3s.prox what

Below, we present examples of questions with modals.

*-Wh Object*

(65) a. √ Xi (dizh) rii'lle'eh rgwèè' Chie'cw? "What Chico can speak?"  
WH.inanimate

b. (\* Rii'lle'eh ) Xi (dizh) rgwèè' Chie'cw? "What Chico can speak?"

*-Wh Subject*

(66) a. √ Tu Rii'lle'eh rgwèè' Dii'zhsah? "Who can speak Zapotec?"  
WH.animate

b. \* Rii'lle'eh Tu rgwèè' Dii'zhsah? "Who can speak Zapotec?"

As observed above, no wh-constituent is allowed between modal auxiliary and complement verb.

The table below, based on the data above, shows that no constituent is allowed between a modal auxiliary and its verb complement.

Table 6. Summary table

| Modal Aux | (*subject)             | complement V |
|-----------|------------------------|--------------|
|           | (*focused constituent) |              |
|           | (*neg)                 |              |
|           | (*wh word)             |              |

Mail contact:

Mario E. Chávez-Peón

Department of Linguistics

University of British Columbia

phone: (604) 822 4256

email: [mariochp@interchange.ubc.ca](mailto:mariochp@interchange.ubc.ca)

E270 1866 Main Mall

Vancouver, BC V6T 1Z1

Canada